

artisanal
Deli

EST 1967



DELI MEATS



SLICE



COLCAB
(PTY) LTD
QUALITY DISPLAY SOLUTIONS

LINEAR 2 DELI



ENERGY EFFICIENT



CUSTOMER SPECIFIC



INNOVATIVE



QUALITY



ROBUST

LINEAR 2 DELI

PRODUCT CODE: L 1040
Available in: 4ft / 6ft / 8ft / 12ft

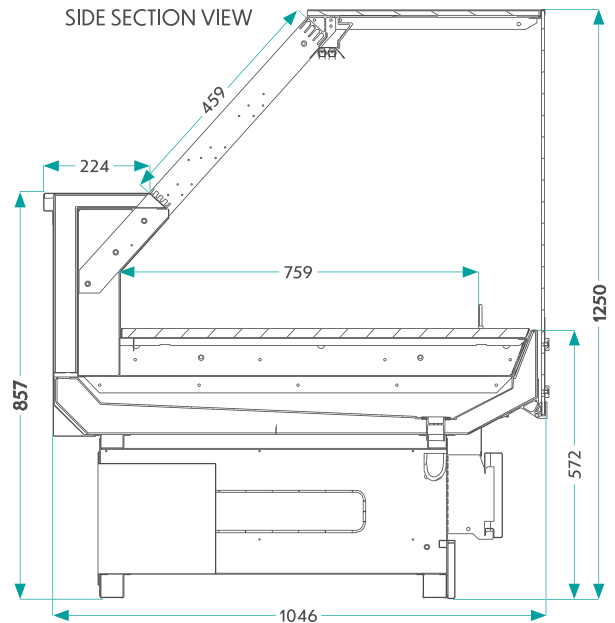
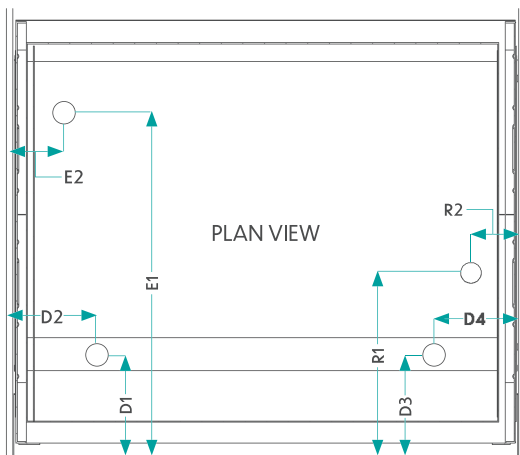

STANDARD SPECIFICATIONS

- Flat Bottom Pan
- Linear Front Bar
- Rear Slider
- Powder-Coated Cladding
- 2 x Probes (Air Off & Defrost)
- Shaded Pole Fan
- Standard Coil
- Valve (Brass Thermostatic)

OPTIONAL SPECIFICATIONS

- 20mm Glass Patch-End with Black Capping
- Solid Patch-End
- Self Contained Unit
- Electronic Valves
- Front Baskets
- ECM Fans

PHYSICAL PROPERTIES

Size	TDA (m ²)	Length (m)
4ft	0.76	1.220
6ft	1.15	1.830
8ft	1.52	2.440
12ft	2.29	3.660

DRAIN POINTS & REFRIGERATION POINTS

	D1	D2	D3	D4	E1	E2	R1	R2
4ft	230mm	609mm	-	-	800mm	110mm	400mm	110mm
6ft	230mm	914mm	-	-	800mm	110mm	400mm	110mm
8ft	230mm	609mm	230mm	609mm	800mm	110mm	400mm	110mm
12ft	230mm	609mm	230mm	600mm	800mm	110mm	400mm	110mm

REFRIGERATION REQUIREMENTS

Refrigeration	Evaporation Temp
110W/ft	-6 °C

Specifications subject to change without notice. Designed for optimal performance in store environments where temperature and humidity do not exceed 25 °C and 60%RH.

ELECTRICAL SPECIFICATIONS

Evaporator Fans Fan Blade + Motor	Lighting Case (LED)	Lighting Shelf (LED)*	Lighting Case (MEAT LED)**
1 x Ø154-28°/36W (SPM) or 24W (ECM)	1x16W	1x16W	2x21W
2 x Ø154-28°/36W (SPM) or 24W (ECM)	1x25W	1x25W	2x31W
2 x Ø154-28°/36W (SPM) or 24W (ECM)	2x16W	2x16W	4x21W
3 x Ø154-28°/36W (SPM) or 24W (ECM)	3x16W	3x16W	6x21W