

BILTONG

EST.



1967

BILTONG



COLCAB
(PTY) LTD
QUALITY DISPLAY SOLUTIONS

LINEAR 2 AMBIENT



ENERGY EFFICIENT



CUSTOMER SPECIFIC



INNOVATIVE



QUALITY



ROBUST

LINEAR 2 AMBIENT

PRODUCT CODE: L 0230
Available in: 4ft / 6ft / 8ft / 12ft

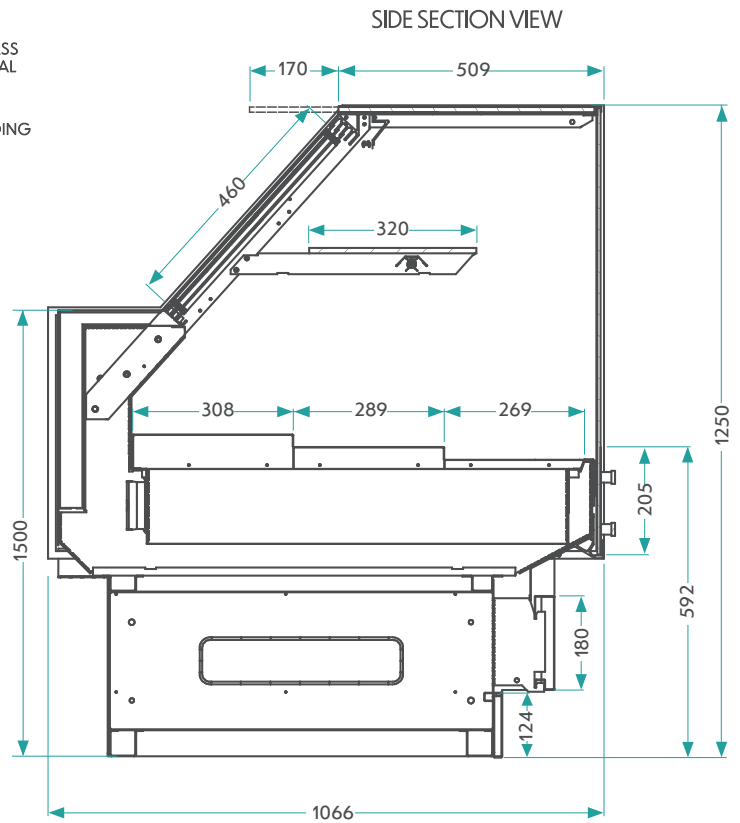
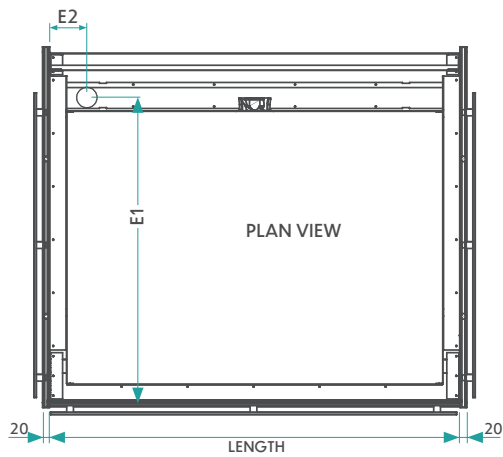
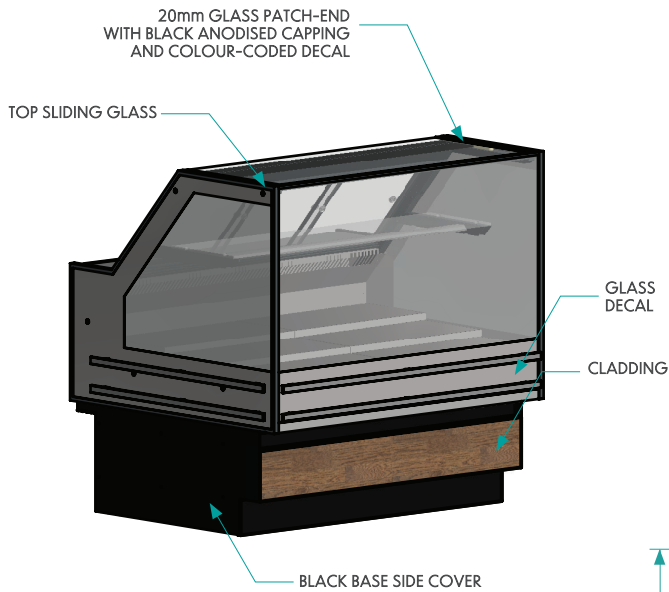

STANDARD SPECIFICATIONS

- Stepped Bottom Pan
- Linear Front Bars
- Rear Sliders
- Powder-Coated Cladding

OPTIONAL SPECIFICATIONS

- 20mm Glass Patch-End with Black Capping
- Solid Colour-Coded Patch-Ends
- Glass Shelf
- Cladding Options:
Refer to Cladding Details Document (Available on Demand)
- 1x LED Wire Shelf
- Front Baskets

PHYSICAL PROPERTIES			DRAIN POINTS & REFRIGERATION POINTS						ELECTRICAL SPECIFICATIONS		
Size	TDA (m ²)	Length (m)	D1	D2	D3	D4	E1	E2	Circulation Fan (ebm 3656)	Lighting Case (LED)	Lighting Shelf (LED)
4ft	1.13	1.218	-	-	-	-	800mm	110mm	1x12W	1x16W	1x16W
6ft	1.72	1.828	-	-	-	-	800mm	110mm	1x12W	1x25W	1x25W
8ft	2.30	2.440	-	-	-	-	800mm	110mm	2x12W	2x16W	2x16W
12ft	3.47	3.660	-	-	-	-	800mm	110mm	2x12W	3x16W	3x16W

Specifications subject to change without notice. Designed for optimal performance in store environments where temperature and humidity do not exceed 25 °C and 60%RH.