



**COLCAB**  
(PTY) LTD  
QUALITY DISPLAY SOLUTIONS

## LINEAR 2 CAKE



ENERGY EFFICIENT



CUSTOMER SPECIFIC



INNOVATIVE



QUALITY



ROBUST

# LINEAR 2 CAKE

**PRODUCT CODE: L 0120**  
Available in: 4ft / 6ft / 8ft / 12ft

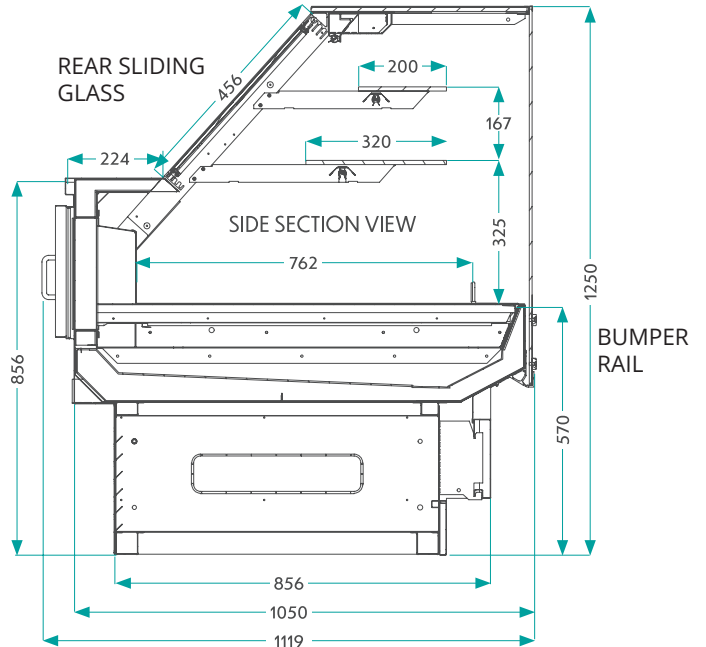
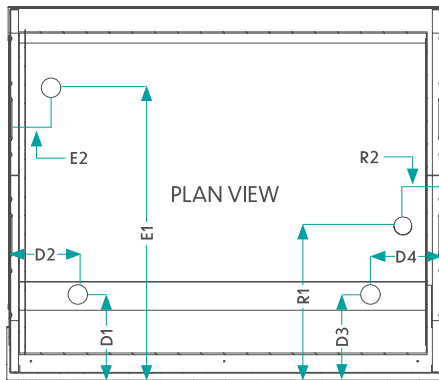

## STANDARD SPECIFICATIONS

- 2 x LED Lit Glass Shelves
- Powder-Coated Cladding
- 2 x Probes (Air Off and Defrost)
- Bumper Rail
- Rear Sliding Glass
- Brass Thermostatic Valve
- Bottom Pans
- Powder-Coated Cladding
- Shaded Pole Fans
- Top Glass Slides Open

## OPTIONAL SPECIFICATIONS

- 20mm Glass Patch-End with Black Capping
- Solid Colour-Coded Patch-Ends
- ECM Fans
- Front Baskets
- Electronic Valves
- Cladding Options:  
Refer to Cladding Details Document (Available on Demand)

## PHYSICAL PROPERTIES

Size	TDA (m <sup>2</sup> )	Length (m)
4ft	1.18	1.220
6ft	1.80	1.830
8ft	2.41	2.440
12ft	3.64	3.660

## DRAIN POINTS & REFRIGERATION POINTS

	D1	D2	D3	D4	E1	E2	R1	R2
4ft	230mm	609mm	-	-	800mm	110mm	400mm	110mm
6ft	230mm	914mm	-	-	800mm	110mm	400mm	110mm
8ft	230mm	609mm	230mm	609mm	800mm	110mm	400mm	110mm
12ft	230mm	609mm	230mm	600mm	800mm	110mm	400mm	110mm

## REFRIGERATION REQUIREMENTS

Refrigeration	Evaporation Temp
94W/ft	-5°C

Specifications subject to change without notice. Designed for optimal performance in store environments where temperature and humidity do not exceed 25°C and 60%RH.

## ELECTRICAL SPECIFICATIONS

Evaporator Fans Fan Blade + Motor	Lighting Case (LED)	Lighting Shelf (LED)
1 x Ø154-28°/36W (SPM) or 24W (ECM)	1x16W	1x16W
2 x Ø154-28°/36W (SPM) or 24W (ECM)	1x25W	1x25W
2 x Ø154-28°/36W (SPM) or 24W (ECM)	2x16W	2x16W
3 x Ø154-28°/36W (SPM) or 24W (ECM)	3x16W	3x16W